



PROJECT: _____
 ITEM # _____ QTY: _____
 MODEL # _____
 AIA # _____ SIS # _____

CUBE ICE MAKER

CUBE ICE MAKER

CIM0836GA90



Features and Benefits

- Uses R290 for a more environmentally friendly and efficient refrigerant.
- Modular design and dual exhaust for flexible application and easy installation on bins or dispensers.
- Easy to clean with front facing evaporator and dishwasher safe (up to 180°F) components.
- Easy and quick cleaning reduces operating costs.
- Simple service with many common parts across all CIM machines.
- Harvest Assist provides consistent ice production for the life of the ice maker while reducing energy consumption and increasing capacity.
- Durable, electroless nickel plating on all evaporator plates ensures reliability.
- Constructed from corrosion-resistant and fingerprint-proof aluminum.

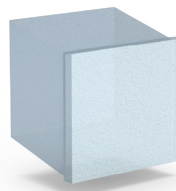

ICE FORMS	
GRANDE CUBE	1 1/4 x 1 1/8 x 7/8 in.
	31 x 29 x 22 mm



BIN CHART									
Model #	B40	B42	B55	B700-30	B110	B1000-48	B1300-48	B1325-60	B1660-60
capacity	344 lbs (156 kg) 30 in (762 mm)	351 lbs (160 kg) 22 in (559 mm)	510 lbs (232 kg) 30 in (762 mm)	680 lbs (308 kg) 30 in (762 mm)	854 lbs (388 kg) 48 in (1,219 mm)	1,000 lbs (454 kg) 48 in (1,219 mm)	1,320 lbs (599 kg) 48 in (1,219 mm)	1,325 lbs (601 kg) 60 in (1,524 mm)	1,660 lbs (753 kg) 60 in (1,524 mm)
Kit for combining wider bins with smaller models	Kit Not Required	Not Compatible	Kit Not Required	Kit Not Required	BPF-1	Kit Not Required	Kit Not Required	Kit Not Required	Kit Not Required

See Ice-O-Matic Price List for Adapter Kits to combine ice makers with most available ice/beverage dispensers.



CIM0836GA90 shown atop of bin B55 (sold separately)

Warranty

- Ice Maker: **3 Years Parts and Labor**
- Evaporator and Compressor: **5 Years Parts**
- Evaporator: **7 Years Parts and Labor**
(if enrolled in the filter program for US & Canada)

Options & Accessories

- KSI-1 - Safe Ice Module
- KCUBEDISPB for mounting to a dispenser
- B55

Water Filter

- Manifold System IFQ2 gets replacement filter IOMQ (2)

11100 E. 45th Avenue • Denver, CO 80239

Phone: 1.866.PURE.ICE

www.iceomatic.com

Rev. 04/2026 Printed in U.S.A.

APPROVAL: _____ DATE: _____



Ice-O-Matic

CUBE ICE MAKER

CIM0836GA90

Line drawing note: Numbers with quote symbol " are in inches. Numbers enclosed in [brackets] are in millimeters.

PLAN / TOP VIEW

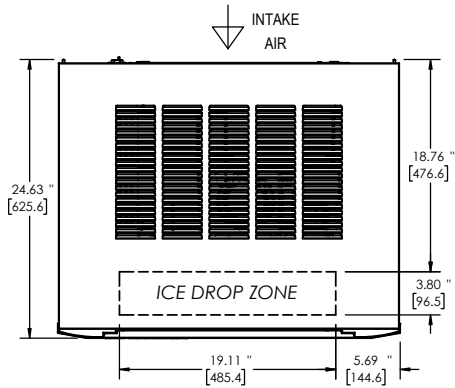

ELEVATION / FRONT VIEW

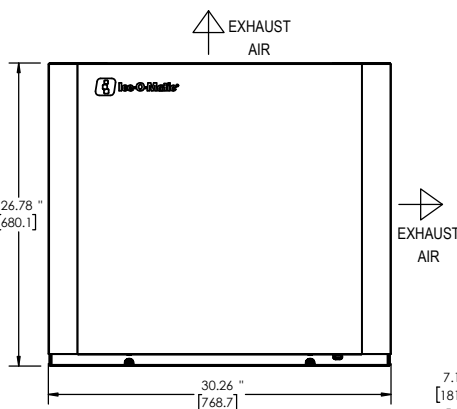

UTILITIES / BACK VIEW

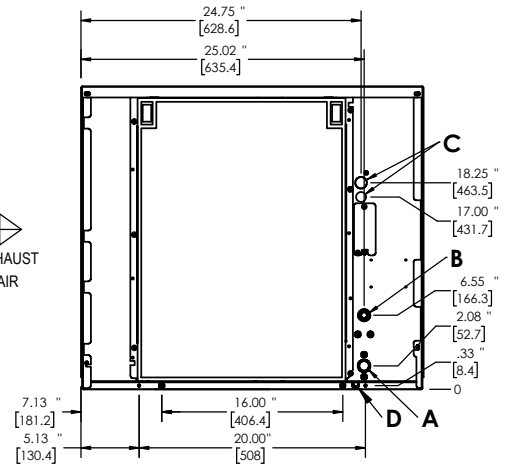

Air Cooled

- A. Ice Maker Drain, 3/4" FPT
- B. Ice Maker Potable Water Inlet, 3/8" FPT
- C. Electrical Connection, Φ .875" [22.2] (2)
- D. Condensate Base Drain, Φ .50" [12.7]

SPECIFICATIONS	
Model	CIM0836GA90
Condensing Type	Air
Voltage/Hertz/Phase	208-230/60/1
Min. Circuit Amp	13.6 A
Max Breaker Size	20 A
KWH per 100 lbs of ice at 70°F air / 50°F water	3.8
KWH per 100 lbs of ice at 90°F air / 70°F water	5.23
BTU (approx per hour)	18165
Number of Wires	3 (including ground)
Refrigerant	R290A
Refrigeration Charge	190 g
Ice Production per 24 hrs	
70° air / 50° water lbs (kg)	90° air / 70° water lbs (kg)
850 (386)	693 (314)
Water Usage gallons per 100 lbs of ice 90°F air / 70°F water	
Potable	Condenser
17	N/A

OPERATING REQUIREMENTS		
	MINIMUM	MAXIMUM
Ambient Temp. Range Air	50°F (10°C)	100°F (38°C)
Water Temp	40°F (4°C)	100°F (38°C)
Water Pressure	20 PSIG (1.4 BAR)	80 PSIG (5.5 BAR)

DIMENSIONS		
Unit Width	30.25 in.	768 mm
Unit Depth	24.25 in.	616 mm
Unit Height	26.9 in.	683 mm
Shipping Weight	212 lbs / 96 kg	
Shipping Dimensions (in.)	33 (W) x 27 (D) x 33 (H)	
Shipping Dimensions (mm)	838.2 (W) x 685.8 (D) x 838.2 (H)	

